

Doro HearingBuds

English



Contents

Overview	1
Get the most out of your HearingBuds	2
Unbox your Doro HearingBuds	2
Getting started	2
Connect and pair	4
Using the earbuds	5
Charging	5
The Doro HearingBuds app	7
Hearing profiles	8
Hearing profile settings	8
Settings	10
Interactive audio test for personalised sound	10
How to clean the earbuds	11
Factory reset	12
Frequently Asked Questions	13
Other	14
Safety instructions	14
Li-Ion battery	15
Protect your hearing	15
Warranty	15
Recycle	16
Correct disposal of this product	16
Correct disposal of batteries in this product	17
EU Declaration of Conformity	17
UK Declaration of Conformity	17
Specifications	17

Overview

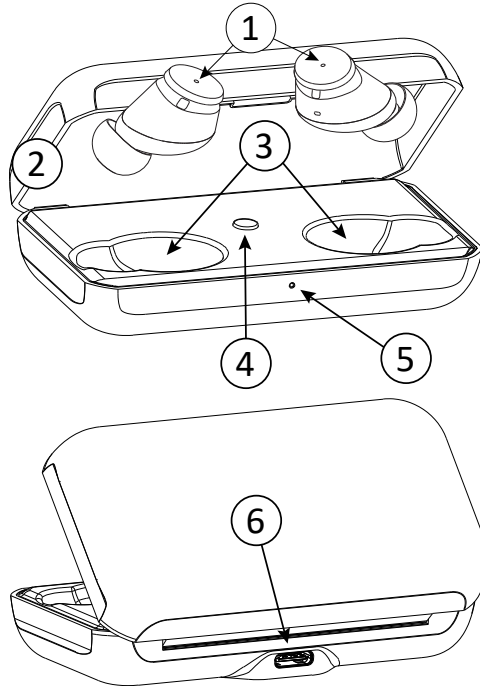

- | | |
|---------------------------|-------------------------------------|
| 1. Earbuds | 5. Indication light |
| 2. Charging case | 6. USB type-C, for battery charging |
| 3. Earbuds charging slots | |
| 4. Pairing button | |

Doro HearingBuds are advanced, true wireless earphones designed with sound experience enhancement technology. They can reduce unwanted noise and make conversations, calls and listening to music both clearer and more comfortable.

IMPORTANT!

Doro HearingBuds is not a medical device, but the earbuds have functionality to improve sound in different situations.

Get the most out of your HearingBuds

Your brain and ears may need some time to get used to the new sound. The human ear is very complex and some things will sound strange at first, but give yourself time to adjust this new sound.

- We recommend wearing your HearingBuds every day at first but take regular breaks.
- Get used to your own voice as this may sound strange to begin with.
- Try your HearingBuds in different environments.

Please also make sure that you after installation is complete, you take the interactive audio test to personalise and optimise the earbuds performance according to your specific hearing.

This is an essential step for a successful experience, see *Interactive audio test for personalised sound*, p.10.

Unbox your Doro HearingBuds

The first step is to unbox the HearingBuds and assess the items and equipment included in the delivery. Make sure to read through the manual so you can familiarise yourself with the equipment and the basic functions. For more information about accessories or other Doro products please visit [doro.com](https://www.doro.com) or contact our Helpline.

Getting started

1. When you open the case, make sure that the lights on the earbuds are activated. If not, check to see if there is a small plastic strip on the charging contacts. You have to remove this plastic strip before you can charge your earbuds.



2. We recommend that you charge the case and the earbuds before you use them, see *Charging*, p.5

3. To optimise the performance you can download the Doro HearingBuds app. In the app you can try different sound settings, see *Hearing profiles*, p.8
4. Select the most comfortable tip size for your ears. There are three different sizes of tips included in the package: black is large, green medium and white is the smallest size.

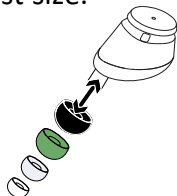

5. Gently insert the silicone tip into the ear canal and position the flat part (with the charging contacts) on the outer ear. There is no left or right, so no need to worry about inserting it into the wrong ear. The earbuds have an automatic left/right ear detection.

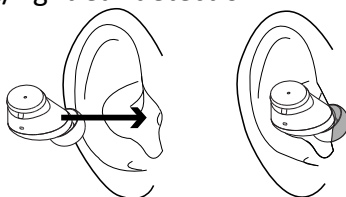

Tip: Try gently pulling the top of your outer ear up to aid fitting them correctly and comfortably. Try different size of the ear tips provided. To ensure a better sound experience, pick the tip size that seals and fits the best with your ear canal.

Connect and pair

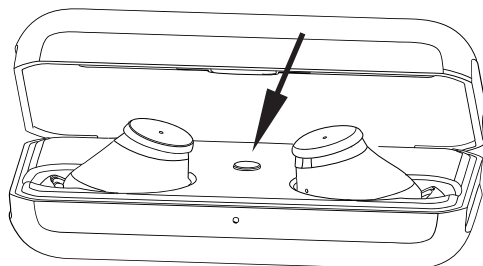

How to connect your HearingBuds via Bluetooth

IMPORTANT!

The HearingBuds must be placed in the charging case before the pairing process is started.

1. First activate Bluetooth on the device you want to pair with the earbuds. On most mobile devices you can find Bluetooth under Settings → Bluetooth.
2. Open the case. Press and hold the **pairing button** until the light in front of the case starts blinking blue.
3. Remove the earbuds from the charging case.

Note! If your connecting device supports Google Fast Pair, Doro HearingBuds will automatically show up for connection. Select Connect/Pair to pair.

4. Go to Settings → Bluetooth on your phone (or other device you have connected).
5. Select “Doro HearingBuds” in the list of available Bluetooth devices and then select Connect/Pair or similar.

Should pairing fail or you want to pair the HearingBuds with a different device, repeat the previous steps.

Using the earbuds

Operating your earbuds is easy. If you want to answer or end a call, or play and pause media, simply tap one of the earbuds twice.

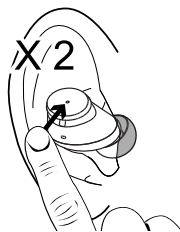

If the sound cuts out while listening, make sure that your Bluetooth connection has not been interrupted. Also make sure that your phone is in a good position, for example in one of your front pockets.

Charging

Note! For environmental reasons this package does not include a charger. The power delivered by the charger must be between minimum 2.5 Watts required by the radio equipment, and maximum 5 Watts in order to achieve the maximum charging speed. You may use chargers with higher power, but it will not increase the charging speed.

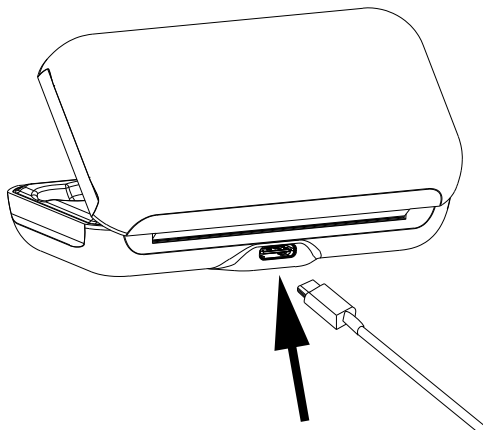

When the earbuds are in the case they will charge automatically. A fully charged case can charge the earbuds fully two times before it needs to be re-charged.

To charge the case, insert a USB-C cable and connect to a power source that has been CE or UKCA certified. Charge the complete product with the earbuds inside the charging case. The light on the front of the case should be blinking slowly while it charges. It will take about three hours until the case is fully charged.

The light on the case changes colour depending on how much it is charged.

- Steady green light = fully charged
- Orange light = battery capacity about 20–80%
- Red light = battery capacity at about 5–20%
- Red and flashing light = battery level is critical, about 0–5%.

If the battery of the earbuds are running low the lights will turn red on one or both of the earbuds. To charge the earbuds, put them back in the case for a while.

The Doro HearingBuds app

Requirements to use the Doro HearingBuds app:

- Android version 8 or later OR iOS version 14 or later.
- A Google account OR an Apple-ID to be able to download and install the Doro HearingBuds app.

To download the app, scan one of the QR codes or use the link for Play Store/App Store:



For Android, scan the QR code for Google Play Store or go to play.google.com



For iOS, scan the QR code for App Store or go to apps.apple.com

IMPORTANT!

Bluetooth must be able to connect with your earbuds in order for the app to work. Allow the necessary permission.

Open and start using the app

- To use the Doro HearingBuds app you need to enable Bluetooth on your device.
- When you open the app it will automatically connect to your Doro HearingBuds.
- You will now get information on how to best use the earbuds and you will also be given the opportunity to do an interactive audio test. The test is designed to optimise and adapt the Doro HearingBuds to your specific hearing, see *Interactive audio test for personalised sound*, p.10 for more information on the audio test.
- You will be able to change between different hearing modes.
- Press  for **Settings**, see *Settings*, p.10 for more information.

Hearing profiles

In the Doro HearingBuds app you can select hearing profiles depending on your hearing needs in different environments. For detailed settings for each profile, see *Hearing profile settings*, p.8.

Tip: Tap  for help.

1. **Speech** to make you hear speech better, for example in a noisy environment.
2. **Natural** to make you hear sounds around you more clearly.
3. **Media** to optimise sound from your TV, radio, cinema or similar environments.
4. **Inactive** to disable all hearing profiles.
5. **Profile volume** to set the general volume for hear-through sound enhancement.
6.  to go to **Settings**, see *Settings*, p.10.

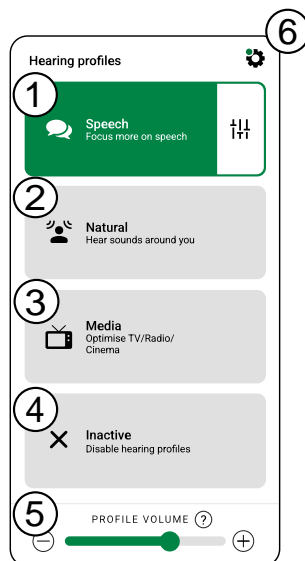

Note! When you are streaming audio from a media device, like a mobile phone, the hearing profiles will automatically be turned off. When the streaming audio is stopped, the hearing enhancement is re-activated with the previous hearing profile.

You can also try changing the focus for even more control over background noise and sounds right in front of you. On each different setting you can tap  to see the focus range of the selected profile, see *Hearing profile settings*, p.8.

Hearing profile settings

Tap  to access the settings for the selected hearing profile.

Tip: Tap  for help.

1. **Focus range** to adjust the focus with the slider (+/-). You can adjust from ambient room sounds (wider focus) to someone speaking right in front of you (more narrow focus).
2. **Fine-tuning** to fine-tune the level of hearing comfort in the selected hearing profile (slider with +/-). The level of hearing compensation is based on the interactive audio test.
3. **Reset** to go back to original settings.

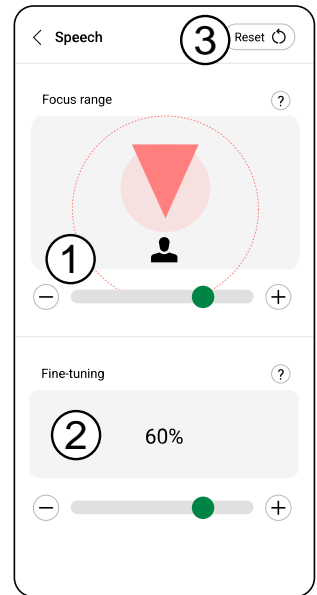

Settings

Tap  to access **Settings**.

1. **Battery indicator** to show the charge of the earbuds (Left L and right R). If you put one earbud back in the case you will notice that this is inactive in the app (the green bar underneath that earbud will turn grey).
2. **Earbud control** to enable/disable gesture control. In this menu you can also enable or disable the **Voice Assistant**.
3. **Updates** to install software updates to your HearingBuds. If an update is available you will get a notification here. Select it to start downloading.
4. **Personalised sound** to take the interactive audio test, see *Interactive audio test for personalised sound*, p.10.
5. **Help** to read more about how to use your HearingBuds.

Tap  to close this menu.

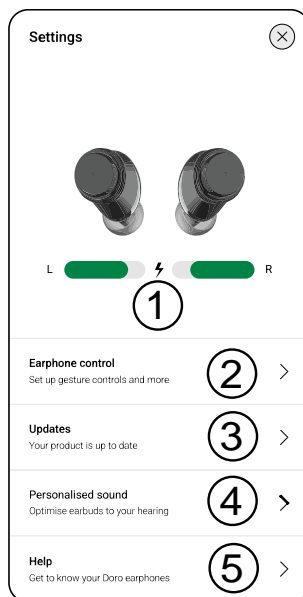

Note! We recommend that you always update your device to the latest software version to get optimal performance and the latest enhancements. The download time may vary depending on Internet connection. By using the device, you accept to install any OS software updates provided by Doro, at earliest possibility after notification. By updating your device, you help to maintain your device secure. Doro will keep updates available for the duration of the guarantee / statutory warranty period, providing that this is possible from a commercial and technical perspective.

Interactive audio test for personalised sound

Take our interactive audio test to optimise the earbuds performance according to your specific hearing. It only takes a few minutes. This is an essential step for a successful experience.

1. **Personalised sound** to find the interactive audio test. The test is designed to optimise and adapt the Doro HearingBuds to your specific hearing.
2. When you start the test, you will get some instructions in the app. Tap **Next** to move forward.
3. To make the result of the hearing test as accurate as possible, make sure that you are in a quiet place when you do the test. Also, make sure that the earbuds are comfortably placed in your ears.
4. When you are ready to start the test, tap **Go** and follow the on-screen instructions.
5. A series of tones will be played, first in one ear and then in the other. All you have to do is tap the indicated area as soon as you hear the tones.
6. You can pause the test at any time and, if you want, continue later. The test will take about four minutes.

Note! The sound test is not intended to replace an in-depth evaluation by a hearing care professional. We recommend that you consult a hearing specialist if you feel that your hearing loss is a problem.

How to clean the earbuds

The silicone ear tips are designed so that dirt and ear wax should not be able to get into the sound canals of the earbuds. Despite this, if you experience lower volume in your earbuds it might be caused by a build-up of dirt or wax. You can clean the earbuds with a slightly damp cloth. To clean the silicone tips, carefully remove them and clean with mild soap and luke-warm water. Do not use solvents when cleaning.

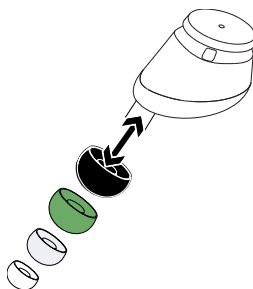

Factory reset

The reason to perform a factory reset might be a persistent problem that is impossible to solve or if you want to pass the Doro HearingBuds to someone else.

1. Place the earbuds inside the charging case and close the lid.
2. Open the lid and press and hold the button inside the case for about 15 seconds. The light will initially blink in blue, but keep on pressing the button until the light will start to blink in bright white, then release the button.
3. Leave the earbuds in the charging case for minimum 30 seconds.
4. Take the earbuds out of the case. Once they start to blink simultaneously, the earbuds are ready for pairing again.

Note! If the earbuds do not blink simultaneously, repeat the process.

To connect the earbuds again, perform the pairing process as in *Connect and pair*, p.4.

Frequently Asked Questions

Question

Where can I find the app for Doro HearingBuds?

Answer

For **Android** users the Doro HearingBuds app can be found by searching the Google Play store or use the QR code below.



For **iOS** users the Doro HearingBuds app is available in App Store or use the QR code below



Find more information at *The Doro HearingBuds app*, p.7.

Question

How do I pair my HearingBuds to my phone?

Answer

If your device supports Google fast pair:

Have the earbuds inside the case and open the lid.

Press the pairing button in the case until the LED light begins to blink in blue, then remove the earbuds.

Press the "Connect"/"Pair" from the pairing pop-up appearing on your phone.

For other users:

1. Press the pairing button in the case until the LED light begins to blink in blue, then take out the earbuds.

2. Go to Bluetooth settings on your phone

3. Select "Doro HearingBuds" from the list to pair

Find more information at *Connect and pair*, p.4.

Question	What is the communication range of the Bluetooth connection, device to earbuds?
Answer	The range of a Bluetooth® connection is approximately 10 meters. However, the maximum communication range will vary depending on obstacles (person, metal, wall, etc.) or electromagnetic disturbance in the environment.
Question	Why do I experience lower volume on my HearingBuds?
Answer	Lower volume is usually caused by a build-up of dirt or wax. Take off the silicone ear tip and clean it if needed. See also <i>How to clean the earbuds</i> , p.11.
Question	Why do I only hear sound in one of my earbuds?
Answer	Something went wrong during the initiation of the connection. Place both earbuds back in the charging case, shortly press the pairing button in the charging case and then take out the earbuds again. If it still fails, please reset the earbuds according to <i>Factory reset</i> , p.12 and then pair the earbuds again, see <i>Connect and pair</i> , p.4.

Other

Safety instructions



CAUTION

The unit and the accessories can contain small parts. Keep all of the equipment out of the reach of small children. The mains adapter is the disconnect device between the product and mains power. The mains socket outlet must be close to the equipment and easily accessible.

Your unit is a technically advanced product and should be treated with the greatest care. Negligence may void the warranty.

- Protect the unit from moisture. Rain, snow, humidity, and all types of liquids can contain substances that corrode the electronic circuits.
- Do not use or keep the unit in dusty, dirty environments.
- Do not keep the unit in warm or cold places.
- Do not drop the unit. Do not knock or shake it either. If it is treated roughly the circuits and precision mechanics can be broken.
- Do not use strong chemicals to clean the unit.

The advice above applies to the unit, battery and other accessories. If the unit is not working as it should, please contact the place of purchase for service. Don't forget the receipt or a copy of the invoice.

Li-Ion battery

This product contains a Li-Ion battery. There is a risk of fire and burns if the battery pack is handled improperly.



WARNING

Danger of explosion if battery is incorrectly replaced. To reduce risk of fire or burns, do not disassemble, crush, puncture, short external contacts, expose to temperature above 60° C (140° F), or dispose of in fire or water. Never use a damaged or swollen battery. Take it to a service point or to your retailer for inspection before continuing to use it. A damaged or swollen battery may present a risk of fire, explosion or leakage or other risk. Recycle or dispose of used batteries according to the local regulations or reference guide supplied with your product.

Removing/replacing the battery

- To remove/replace the battery, contact an authorised service centre. Please find latest information at www.doro.com.
- For your safety, you must not attempt to remove the battery. If the battery is not properly removed, it may lead to damage to the battery and device, cause personal injury, and/or result in the device being unsafe.
- Doro does not accept liability for any damage or loss if these warnings and instructions are not followed.

Protect your hearing



WARNING

Excessive exposure to loud sounds can cause hearing damage. Exposure to loud sounds while driving may distract your attention and cause an accident. Listen to audio at a moderate level.

Warranty

This product is guaranteed for a period of 24 months and for original accessories for a period of 12 months (such as the charger and cable) which may be delivered with your device, from the date of purchase. In the unlikely event of a fault occurring during this period, please contact the place of purchase. Proof of purchase is required for any service or support needed during the guarantee period.

This guarantee will not apply to a fault caused by an accident or a similar incident or damage, liquid ingress, negligence, abnormal usage, non-maintenance or any other circumstances on the user's part. Furthermore, this guarantee will not apply to any fault caused by a thunderstorm or any other voltage fluctuations. As a matter of precaution, we recommend disconnecting the charger during a thunderstorm.

Please note that this is a voluntary manufacturer's warranty and provides rights in addition to, and does not affect statutory rights of end-users.

This guarantee does not apply if batteries other than DORO original batteries are used.

Device OS software warranty

By using the device, you accept to install any software updates provided by Doro, at earliest possibility after notification.

By updating your device, you help to maintain your device secure.

Doro will keep updates available for the duration of the guarantee/ statutory warranty period, providing that this is possible from a commercial and technical perspective.

Your device checks for available software updates automatically. Please follow the on-screen instructions when you are notified of a software update.

Please note:

- In some cases, regular upgrades may cause delays to planned security updates.
- Doro will always do our best to deliver the security updates at earliest possible time to applicable models. Delivery time of security patches may vary depending on the regions, software variants and models.



CAUTION

If you neglect to update your device after being notified, it may void your guarantee of the device. For software information and planned update schedule, refer to website: doro.com/softwareupdates

Recycle

Doro takes responsibility for the entire life cycle of our products including how they are recycled at end of their life. Your previous product can still be useful for someone else and, if it has reached its end of life, materials that can be used for new products. We recommend to first-hand reuse, repair or refurbish your device, and if this is not possible leave it for recycling according to local regulations. Also remember to recycle other old non-used electronics that you might have.

Correct disposal of this product



(Waste Electrical & Electronic Equipment)

(Applicable in countries with separate collection systems)

This marking on the product, accessories or manual indicates that the product and its electronic accessories (e.g. charger, headset, USB cable) should not be disposed of with other household waste. To prevent possible harm to the environment or human health from uncontrolled waste disposal, please separate these items from other types of waste and recycle them responsibly to promote the sustainable reuse of material resources. Household

users should contact either the retailer where they purchased this product, or their local government office, for details of where and how they can take these items for environmentally safe recycling. Business users should contact their supplier and check the terms and conditions of the purchase contract. This product and its electronic accessories should not be mixed with other commercial wastes for disposal. This product is RoHS compliant.

Correct disposal of batteries in this product



(Applicable in countries with separate collection systems)

The marking on the battery, manual or packaging indicates that the battery in this product should not be disposed of with other household waste. If batteries are not properly disposed of, these substances can cause harm to human health or the environment.

To protect natural resources and to promote material reuse, please separate batteries from other types of waste and recycle them through your local, free battery return system.

EU Declaration of Conformity

Hereby, Doro declares that the radio equipment type DWO-0430 (Doro HearingBuds) is in compliance with Directive 2014/53/EU and other applicable legislations.

The full text of the EU declaration of conformity is available at the following internet address: www.doro.com/dofc.

UK Declaration of Conformity

Hereby, Doro declares that the radio equipment type DWO-0430 (Doro HearingBuds) is in compliance with the relevant UK legislation.

The full text of the UK declaration of conformity is available at the following internet address: www.doro.com/dofc

Specifications

Bluetooth (MHz):		5.0, (2402 - 2480)
Dimensions	Case:	88 x 47 x 26 mm
	1 Bud:	16 x 17 x 20 mm
Weight	Case:	57 g
	1 Bud:	6 g
Battery	Case:	3.7 V / 700 mAh Li-Ion
	1 Bud:	battery g 3.7 V / 85 mAh Li-Ion battery g
Charging time	Case:	3 hours
	Buds:	105 minutes

Battery life	Case: Buds:	2 full charges of 2 earbuds Up to 11 hours
Waterproof:	Case: Buds:	— Drip protected (IP52)
Operating ambient temperature:		Min: -5° C Max: 45° C
Charging ambient temperature:		Min: -5° C Max: 40° C

Bluetooth® is a registered trademark of Bluetooth SIG, Inc.

Other product and company names mentioned herein may be the trademarks of their respective owners.

Any rights not expressly granted herein are reserved. All other trademarks are property of their respective owners.

To the maximum extent permitted by applicable law, under no circumstances shall Doro or any of its licensors be responsible for any loss of data or income or any special, incidental, consequential or indirect damages howsoever caused.

Doro does not provide a warranty for or take any responsibility for the functionality, content, or end-user support of third-party apps provided with your device. By using an app, you acknowledge that the app is provided as is. Doro does not make any representations, provide a warranty, or take any responsibility for the functionality, content, or end-user support of third-party apps provided with your device.

This device is a low-power radio transmitter and receiver. As recommended by international guidelines, the device meets applicable national SAR limits of 2.0W/kg (10g). 10g SAR: meets low-power exclusion level, SAR test is not required.

This product can be used across EU member states.

DWO-0430 () (2011,2021,3011)

English

Version 2.0

©20232023 Doro AB. All rights reserved.

www.doro.com



REV 21851 – STR 20230626